

*k. Shirai*

APPROVED BY:

DATE:

*Y. Y. Mar 9, 2000*

## ELECTRONIC COMPONENTS GROUP SHARP CORPORATION SPECIFICATION

.DEVICE SPECIFICATION FOR

VOLTAGE REGULATOR

Applied model name

MODEL No.

**PQ070XZ01Z****PQ070XZ01ZZ****PQ070XZ01ZP**

1. These specification sheets include materials protected under copyright of Sharp Corporation ("Sharp"). Please do not reproduce or cause anyone to reproduce them without Sharp's consent.
2. When using this product, please observe the absolute maximum ratings and the instructions for use outlined in these specification sheets, as well as the precautions mentioned below. Sharp assumes no responsibility for any damage resulting from use of the product which does not comply with the absolute maximum ratings and the instructions included in these specification sheets, and the precautions mentioned below.

**(Precautions)**

- (1) This product is designed for use in the following application areas :

- OA equipment    • Audio visual equipment    • Home appliances
- Telecommunication equipment (Terminal)    • Measuring equipment
- Tooling machines    • Computers

If the use of the product in the above application areas is for equipment listed in paragraphs (2) or (3), please be sure to observe the precautions given in those respective paragraphs.

- (2) Appropriate measures, such as fail-safe design and redundant design considering the safety design of the overall system and equipment, should be taken to ensure reliability and safety when this product is used for equipment which demands high reliability and safety in function and precision, such as :

- Transportation control and safety equipment (aircraft, train, automobile etc.)
- Traffic signals    • Gas leakage sensor breakers    • Rescue and security equipment
- Other safety equipment

- (3) Please do not use this product for equipment which require extremely high reliability and safety in function and precision, such as :

- Space equipment    • Telecommunication equipment (for trunk lines)
- Nuclear power control equipment    • Medical equipment

- (4) Please contact and consult with a Sharp sales representative if there are any questions regarding interpretation of the above three paragraphs.

3. Please contact and consult with a Sharp sales representative for any questions about this product.

CUSTOMER'S APPROVAL

DATE

BY

DATE

PRESENTED

BY

*K. H*

K. Hachimura,  
Department General Manager of  
Engineering Dept..II  
Opto-Electronic Devices Div.  
ELECOM Group  
SHARP CORPORATION

**REFERENCE**

## 1. Application

This specification applies to the outline and characteristics of series regulator (linear type), Model No. PQ070XZ01Z.

## Usage

PQ070XZ01Z is the device for stabilization of positive output voltage with built-in ON/OFF function, the over current protection function, the overheat protection function, adjustable DC output voltage by using external resistance and low consumption current at OFF-state (stand-by). These devices are possible to use in power supply circuit up to current capacity 1.0A.

## Block diagram

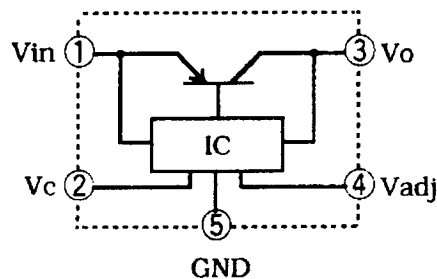

2. Outline : Refer to the attached sheet, Page 3.
3. Ratings and characteristics : Refer to the attached sheet, page 4 to 8.
  - 3.1 Absolute maximum ratings
  - 3.2 Electrical characteristics
  - 3.3 Electrical characteristics measuring circuit
  - 3.4 Pd-Ta rating (Typical value)
4. Reliability : Refer to the attached sheet, Page 9, 10.
5. Outgoing inspection : Refer to the attached sheet, Page 10.

6. Supplement : Refer to the attached sheet, Page 11 to 17.

- 6.1 Example of application
- 6.2 Output voltage adjustment characteristics
- 6.3 Taping and reel packaging (PQ070XZ01ZP)
- 6.4 Sleeve packaging (PQ070XZ01ZZ)
- 6.5 ODS materials

This product shall not contain the following materials.  
Also, the following materials shall not be used in the production process for this product.

Materials for ODS : CFC<sub>s</sub>, Halon, Carbon tetrachloride,  
1.1.1-Trichloroethane (Methylchloroform)

6.6 Brominated flame retardants

Specific brominated flame retardants such as the PBBO<sub>s</sub> and PBB<sub>s</sub> are not used in this device at all.

6.7 This product is not designed as electromagnetic and ionized-particle radiation resistant.

7. Notes : Refer to the attached sheet, Page 18 to 21.

- 7.1 External connection
- 7.2 Thermal protection design
- 7.3 Static electricity
- 7.4 Soldering
- 7.5 For cleaning

**REFERENCE**

2. Outline

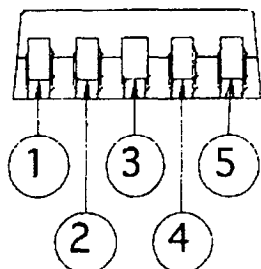
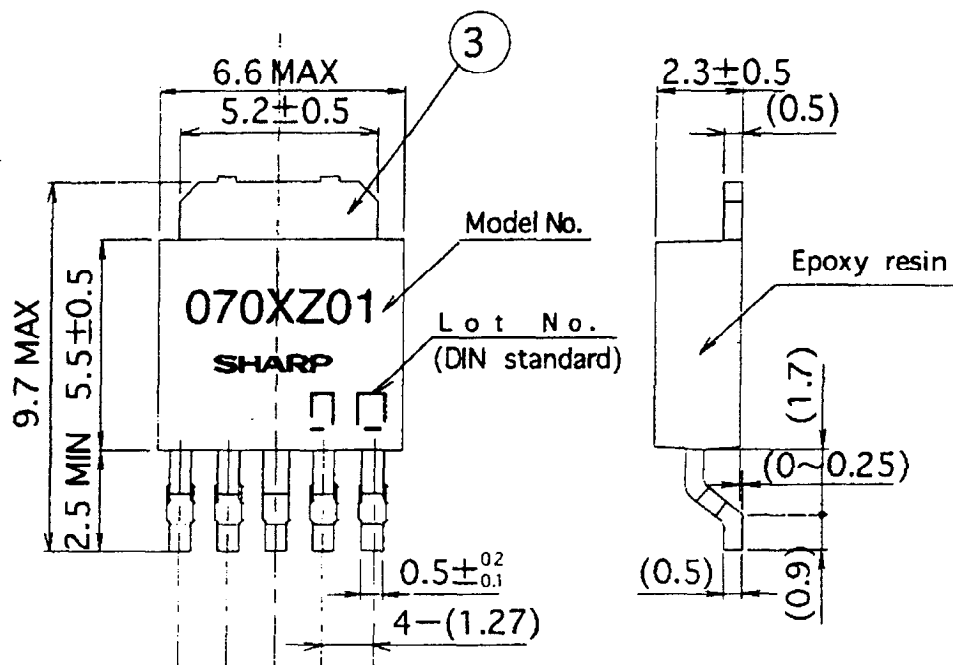

- 1 DC input (Vin)
- 2 ON/OFF control (Vc)
- 3 DC output (Vo)
- 4 Output voltage adjustment (Vadj)
- 5 GND

• ( ) : TYP.  
 • Unit : mm  
 • Scale : 5/1

Applied model No.	Marked model No.
PQ070XZ01ZZ	070XZ01
PQ070XZ01ZP	070XZ01

• Lead finish : Solder plating  
 • Lead material : Cu  
 • Product mass : 0.3g

## 3. Ratings and characteristics

## 3.1 Absolute maximum ratings

Ta=25°C

Parameter	Symbol	Rating	Unit	Conditions
Input voltage (*1)	Vin	10	V	
ON/OFF control voltage (*1)	Vc	10	V	
Output adjustment pin voltage (*1)	Vadj	5	V	
Output current	Io	1	A	
Power dissipation (*2)	Pd	8	W	Refer to Fig. 1
Junction temperature (*3)	Tj	150	°C	
Operating temperature	Topr	-40 to +85	°C	
Storage temperature	Tstg	-40 to +150	°C	
Soldering temperature	Tsol	260	°C	For 10 s

(\*1) All are open except GND and applicable terminals.

(\*2) Pd : With infinite heat sink

(\*3) There is case that over heat protection operates at the condition Tj=125°C to 150°C

Fig. 1 Pd - Ta rating

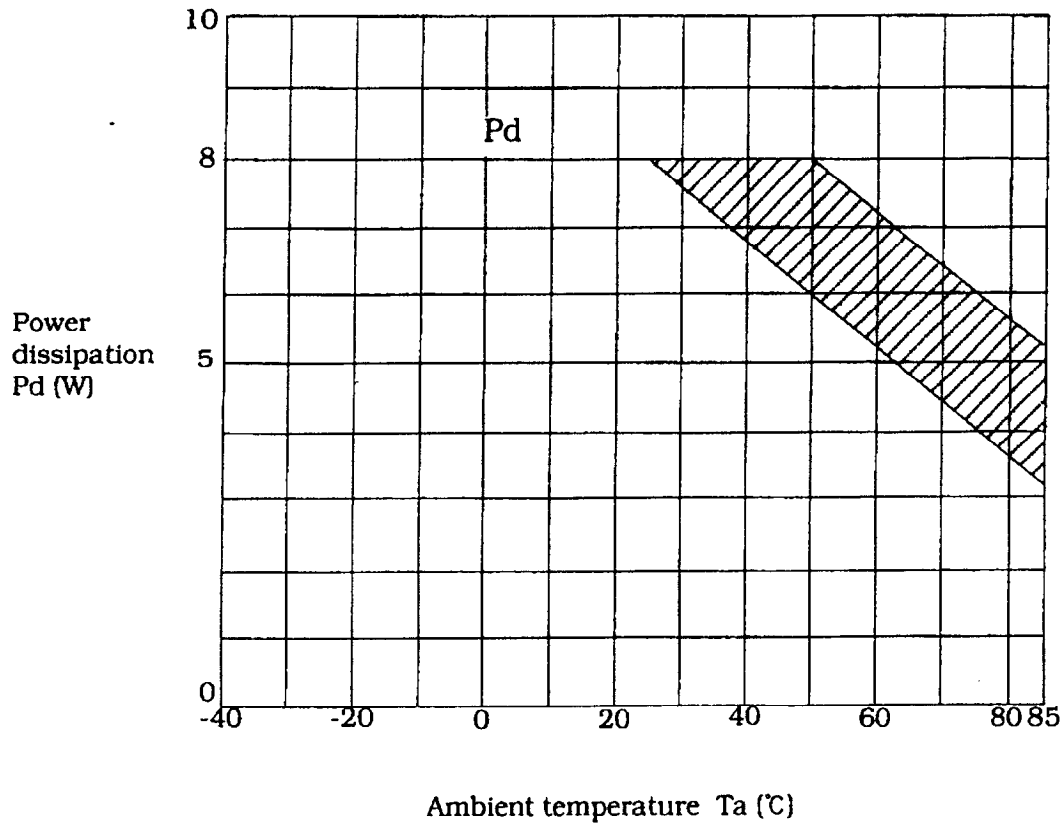

Pd : With infinite heat sink

(Note) There is case that over heat protection function operates at oblique line portion.

**REFERENCE**

## 3.2 Electrical characteristics

Unless otherwise specified condition shall be  
 $V_{in}=5V$ ,  $V_o=3V$  ( $R_1=1k\Omega$ ),  $I_o=0.5A$ ,  $V_c=2.7V$

$T_a=25^\circ C$

Parameter	Symbol	MIN.	TYP.	MAX.	Unit	Conditions
Input voltage	$V_{in}$	2.35	-	10	V	
Output voltage	$V_o$	1.5	-	7	V	
Load regulation	RegL	-	0.2	2.0	%	$I_o=5mA$ to 1.0A
Line regulation	RegI	-	0.2	1.0	%	$V_{in}=4$ to 8V $I_o=5mA$
Ripple rejection	RR	45	60	-	dB	Refer to Fig.3
Dropout voltage	$V_{i-o}$	-	-	0.5	V	$V_{in}=2.85V$ , $I_o=0.5A$
Reference voltage	$V_{ref}$	1.225	1.25	1.275	V	
Temperature coefficient of reference voltage	$T_c V_{ref}$	-	$\pm 1.0$	-	%	$T_j=0$ to $125^\circ C$ $I_o=5mA$
On-state voltage for control	$V_c$ (on)	2.0	-	-	V	(*4)
On-state current for control	$I_c$ (on)	-	-	200	$\mu A$	
Off-state voltage for control	$V_c$ (off)	-	-	0.8	V	$I_o=0A$
Off-state current for control	$I_c$ (off)	-	-	2	$\mu A$	$I_o=0A$ , $V_c=0.4V$
Quiescent current	$I_q$	-	1	2	mA	$I_o=0A$
Output off-state consumption current	$I_{qs}$	-	-	5	$\mu A$	$V_c=0.4V$

(\*4) In case of opening control terminal (2th pin), output voltage turns OFF.

3.3 Electrical characteristics measuring circuit

Fig. 2 Standard measuring circuit of Regulator portion

$$V_o = V_{ref} \times (1 + R_2/R_1)$$

$$\approx 1.25 \times (1 + R_2/R_1)$$

( $R_1 = 1k\Omega$ ,  $V_{ref} \approx 1.25V$ )

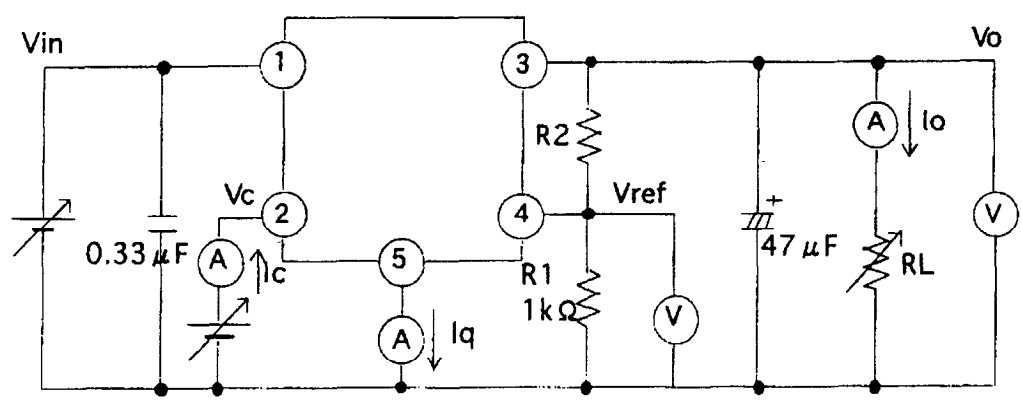
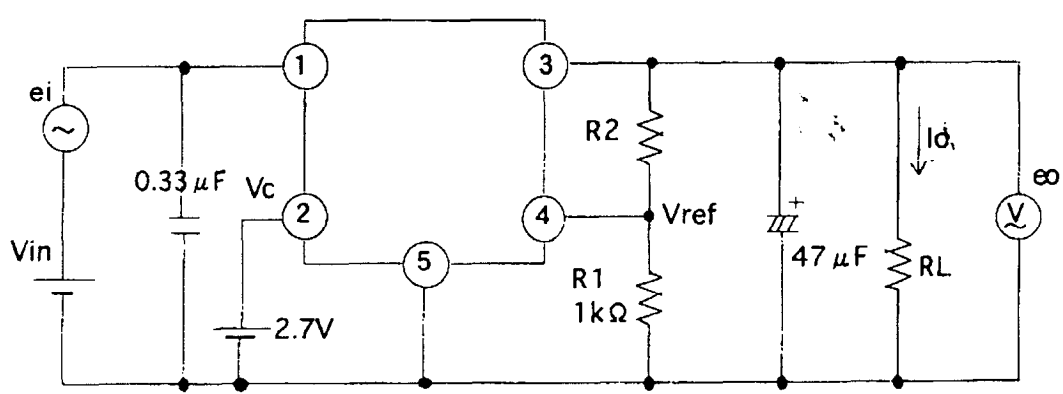

Fig. 3 Standard measuring circuit of critical rate of ripple rejection

$f = 120Hz$  sine wave  
 $e_i(rms) = 0.5V$   
 $V_{in} = 5V$   
 $V_o = 3V$  ( $R_1 = 1k\Omega$ )  
 $I_o = 0.3A$   
 $RR = 20 \log \{ e_i(rms) / e_o(rms) \}$





3.4 Pd - Ta rating (Typical value)

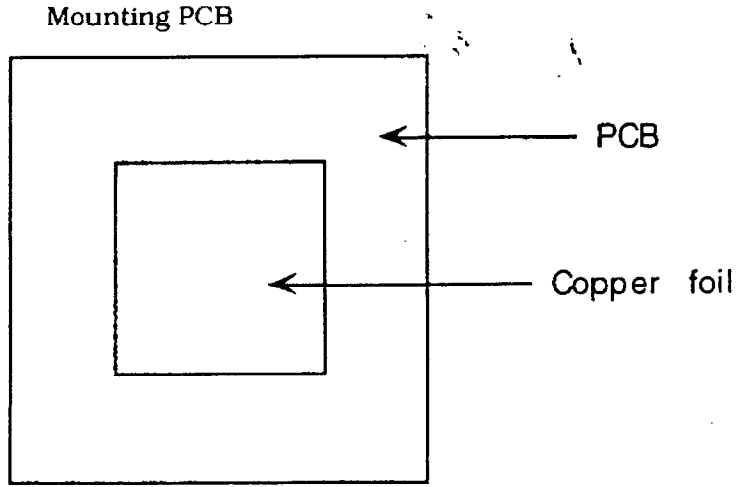
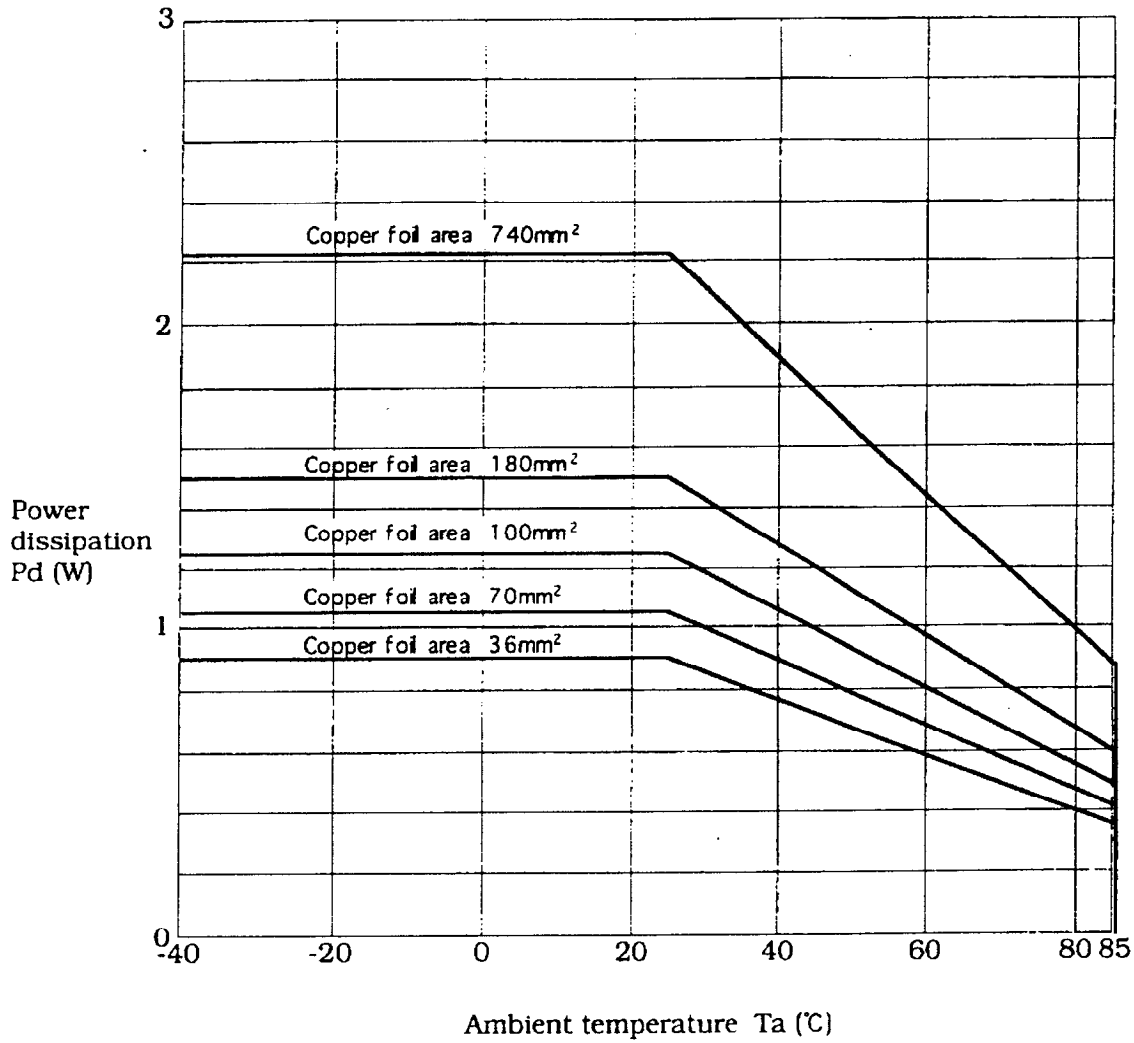

Material : Glass-cloth epoxy resin  
Size : 50 × 50 × 1.6mm  
Thickness of copper : 35 μm

REFERENCE

## 4. Reliability

The reliability of products shall satisfy items listed below.

Confidence level : 90%

LTPD : 10%/20%

Test Items	Test Conditions	Failure Judgement Criteria	Samples (n) Defective(C)
Temperature cycling	1 cycle -40°C to +150°C (30min) (30min) 20 cycles test	$V_{ref} < L \times 0.8$	n=22, C=0
Humidity (Steady State)	+60°C, 90%RH, 1000h	$V_{ref} > U \times 1.2$	n=22, C=0
Damp Heat cyclic	1 cycle : -20°C to 70°C (2h) (2h) Transfer time between high and low temp. is 1h. 40 cycles test. 90%RH	$RegL > U \times 1.2$ $RegI > U \times 1.2$	n=22, C=0
High temp. storage	+150°C, 1000h	$RR < L \times 0.8$	n=22, C=0
Low temp. storage	-40°C, 1000h	$Vi-o > U \times 1.2$	n=22, C=0
Operation life	Ta=25°C, Pd=0.8W, 1000h		n=22, C=0
Mechanical shock	15000m/s <sup>2</sup> , 0.5ms 3 times/ ±X, ±Y, ±Z		n=11, C=0
Vibration (Variable frequency)	200m/s <sup>2</sup> , 100 to 2000 to 100Hz/4 min 4 times/ X, Y, Z direction	U: Upper specification limit	n=11, C=0
Electrostatic discharge	±250V, 200pF, 0Ω Between GND and each terminal/ 3 times	L: Lower specification limit	n=11, C=0
Soldering heat	260°C, 10 s. Dip up to 0.5mm from resin portion *1		n=11, C=0
Robustness of Termination (Tensile test)	Weight: 10N 10 s/ each terminal *2	Failure if it has breakdown and loosened pin. *4	n=11, C=0
Robustness of Termination (Bending test)	Weight: 2.5N 0° ~90° ~0° ~-90° ~0° each terminal *3		n=11, C=0
Solderability	230±5°C, 5±0.5 s Use rosin flux *1	Failure if solder shall not be adhere at the area of 95% or more dipped portion. *5	n=11, C=0

\*1 Soldering area is shown below.

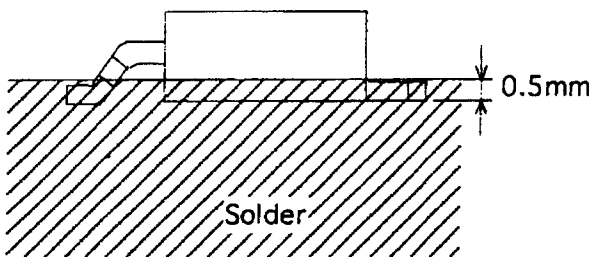

\*2 Terminal tensile direction is shown below.

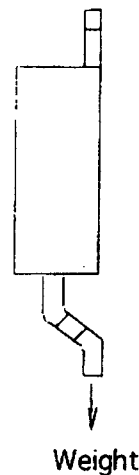

\*3 Terminal bending direction is shown below.

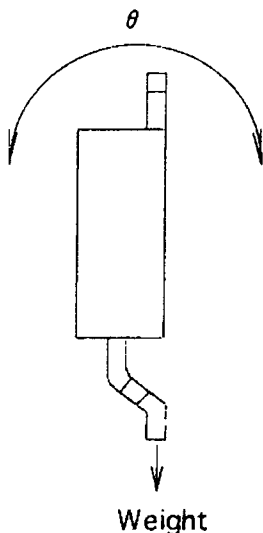

\*4 Except for the bending of terminal.

\*5 Except for the portion within 0.5mm from the interface between the heat sink and the resin portion, and the side surface of heat sink.

5. Outgoing inspection

TABLE II-A single sampling plans for normal inspection based on ISO 2859 is applied. The AQL according to the inspection items are shown below.

Defect	Inspection items	AQL (%)	Judgement criteria
Major defect	Electrical characteristics	0.1	Depend on the specification
	Unreadable marking		
Minor defect	Appearance	0.4	
	Dimensions		

**REFERENCE**

6. Supplement

6.1 Example of application

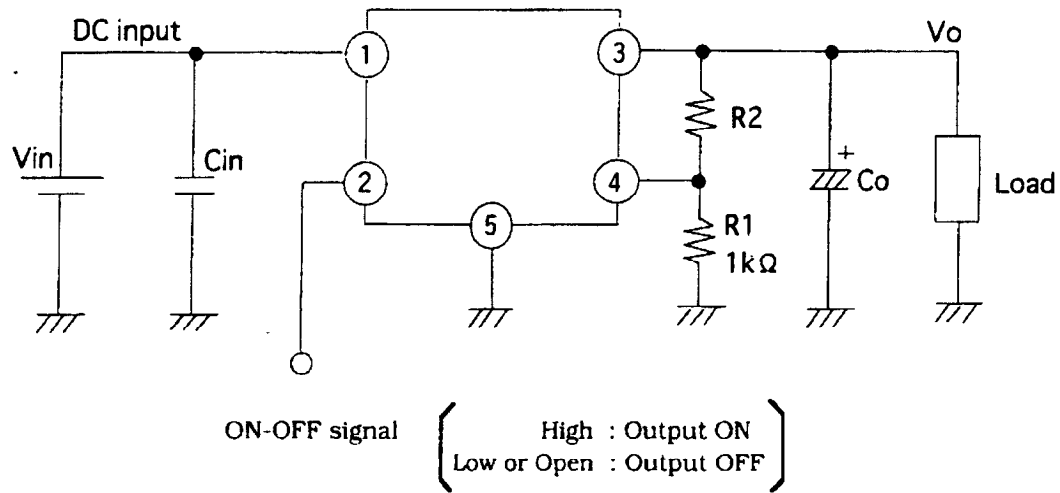

6.2 Output voltage adjustment characteristics

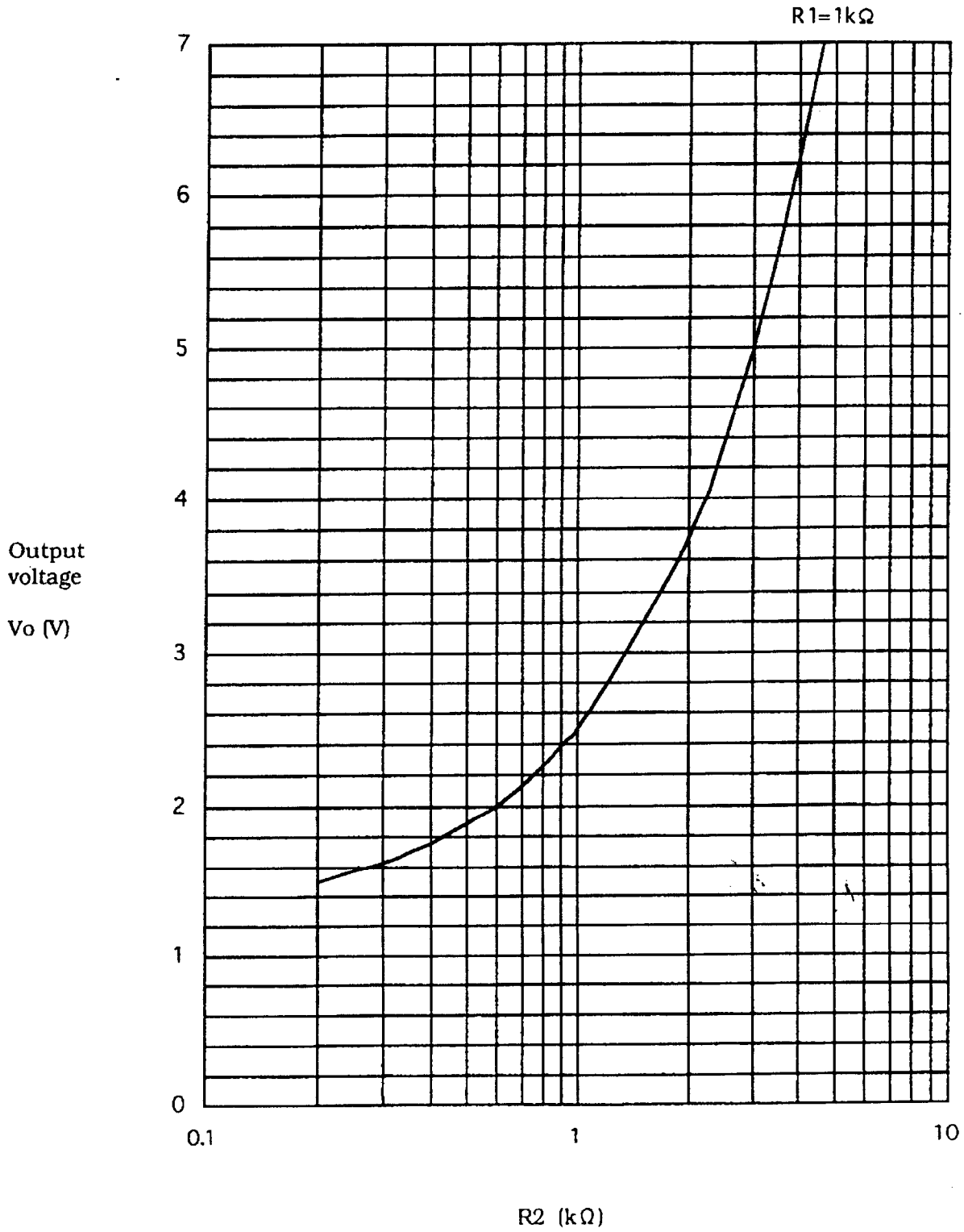

**REFERENCE**

### 6.3 Packing specifications (PQ070XZ01ZP)

#### 6.3.1 Packing conditions

(1) Tape structure and Dimensions (Refer to Fig. A)

The tape shall have a structure in which a cover tape is sealed heat-pressed on the carrier tape of polystyrene emboss protect against static electricity. Dimensions are shown Fig. A.

(2) Reel structure and Dimensions (Refer to Fig.B)

The reel shall be made of polystyrene. Dimensions are shown Fig. B.

(3) Direction of product insertion (Refer to Fig. C)

Product direction in carrier tape shall direct to the radiate fin of product at the hole side on the tape.

#### 6.3.2 Tape characteristics

(1) Adhesiveness of cover tape

The peel-back force between carrier tape and cover tape shall be 0.1N to 0.8N for the angle from 160° to 180°. (Tape speed : 5mm/s)

(2) Bending strength

Sealed tape : Bended tape radius shall be more than 30mm.  
If bended tape radius is less than 30mm,  
there is case that cover tape come off carrier tape.

(3) Carrier tape : Bended tape radius shall be more than 15mm.

#### 6.3.3 Rolling method and quantity

(1) Rolling method

Wind the tape back on the reel so that the cover tape will be outside the tape. Attach more than 20 pitch of empty cavities to the trailer and attach more than 10 pitch of empty cavities to the leader of the tape and fix the both ends with adhesive tape.

(2) Quantity

One reel shall contain 3000 pcs.

REFERENCE

6.3.4 Indication

(1) Reel

The reel shall be pasted label with following information.

- \* Model No.
- \* Number of pieces contained
- \* Production date

(2) Package case

The outer packaging case shall be marked with following information.

- \* Model No.
- \* Number of pieces contained
- \* Inspection date

6.3.5 Storage condition

Taped products shall be stored at the temperature lower than 5 to 30°C and the humidities lower than 70%RH. If taped products aren't used longer than for 10 days, Please rewind the tape pulled out and storage.

6.3.6 Others

(1) joint of tape

The cover tape and carrier tape in one reel shall be jointless.

(2) The way to repair taped failure devices

The way to repair taped failure devices cut a bottom of carrier tape with a cutter, and after replacing to good devices, the cutting portion shall be sealed with adhesive tape.

Fig. A Tape structure and Dimensions

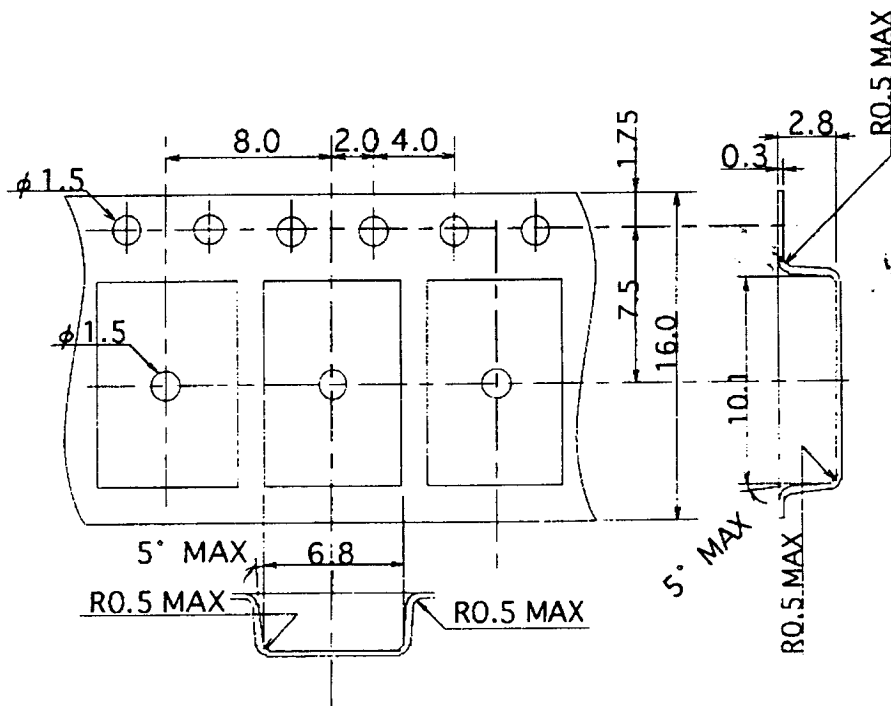

Dimensions : TYP. value  
Unit : mm

**REFERENCE**

Fig. B Reel structure and Dimensions

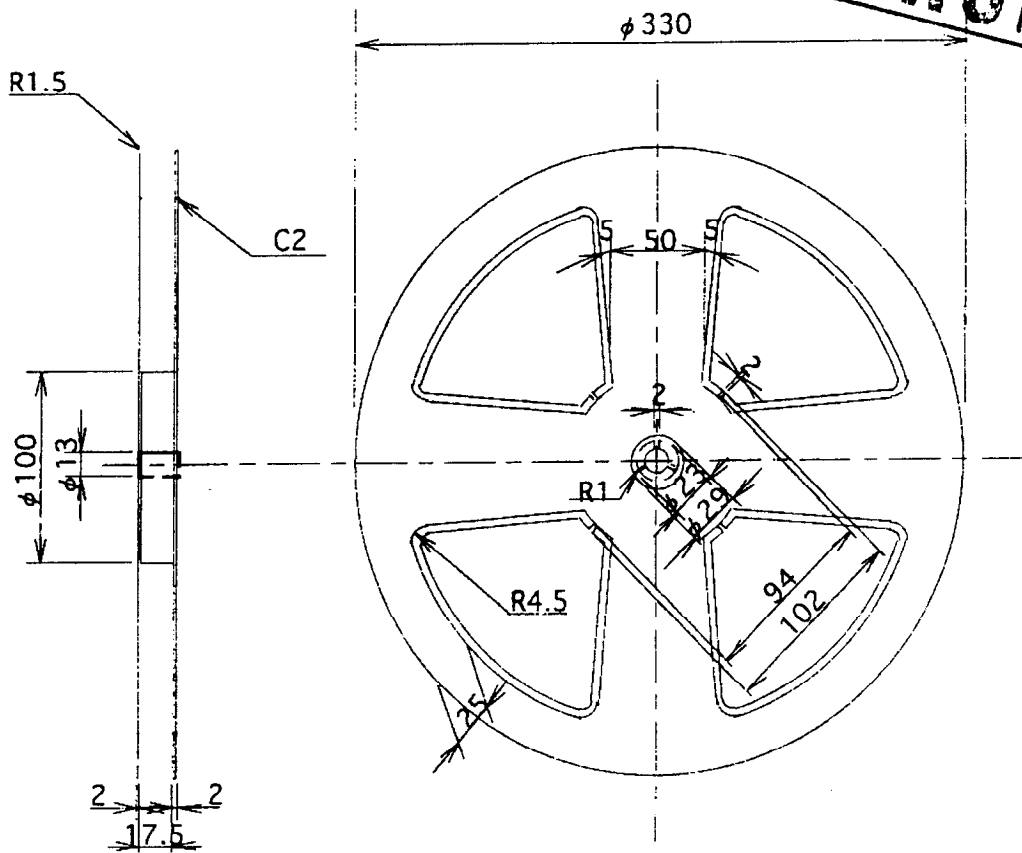

Dimensions : TYP. value  
Unit : mm

Fig. C Direction of product insertion

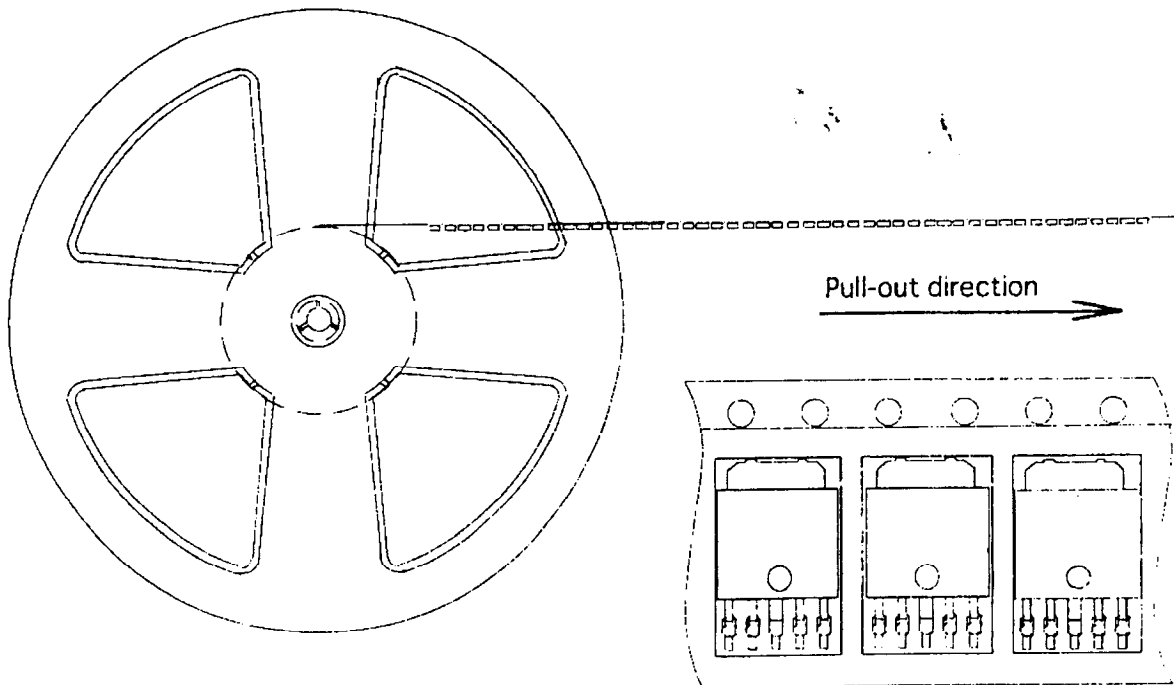



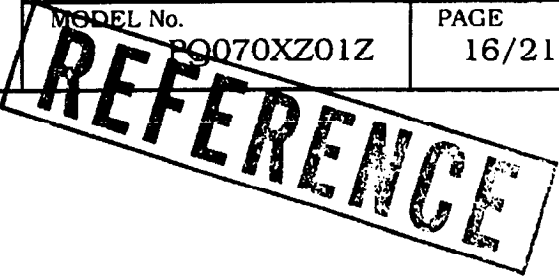

6.4 Sleeve packaging (PQ070XZ01ZZ)

6.4.1 Packing conditions

- (1) Sleeve structure and Dimensions (Refer to Fig. D)

The sleeve shall be made of high impact polyethylene (Plastics with preventing static electricity). Dimensions are shown Fig. D.

- (2) The packing case shall be made of corrugated cardboard. Dimensions are shown Fig. F.

- (3) Stopper structure

The stopper shall be made of styrene butadiene rubber.

6.4.2 Packaging method and quantity

- (1) Packaging method

Max. 75pcs. of products shall be packaged in a sleeve and both of sleeve edges shall be fixed by stoppers. Fix the packing case by kraft tape.

- (2) Quantity (Refer to Fig. E)

One package shall contain 3000pcs./package.

6.4.3 Indication

- (1) Packing case

The packing case shall be marked with following information.

\* Model No.   \* Number of pieces contained   \* Inspection date

**REFERENCE**

Fig. D

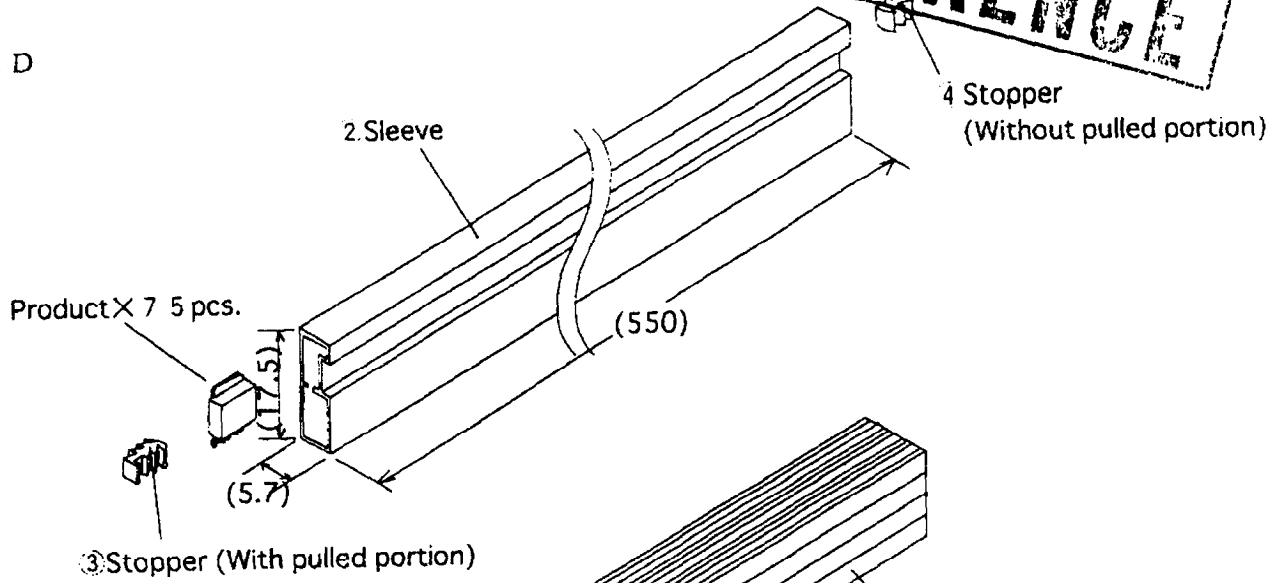

Fig. E

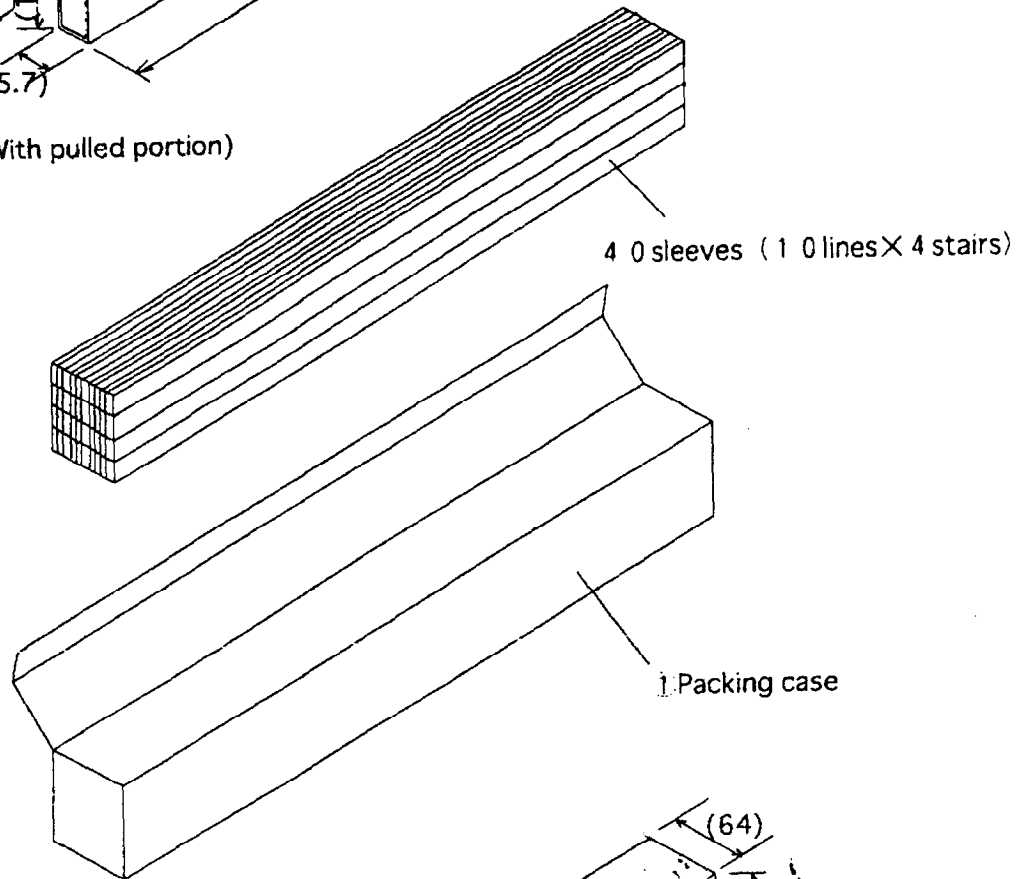
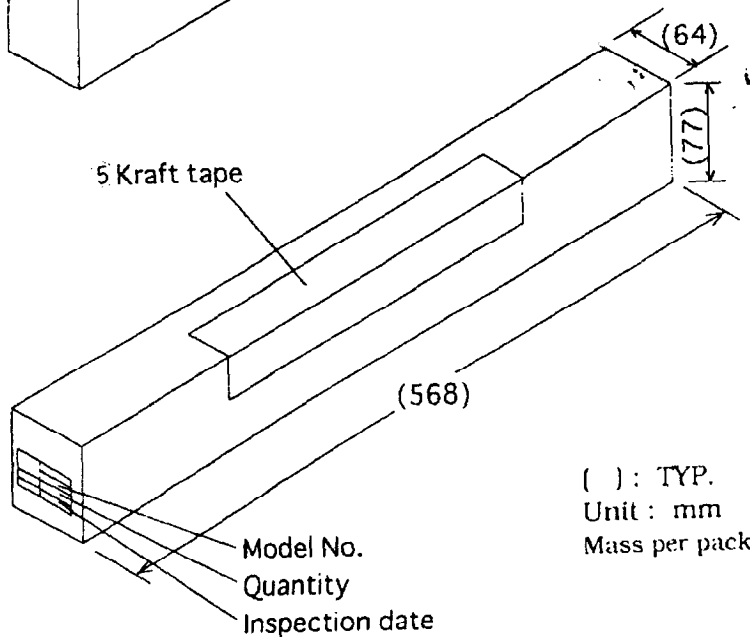

Fig. F



( ): TYP.

Unit : mm

Mass per packaged case : 1.6kg TYP

REFERENCE

## 7. Notes

## 7.1 External connection

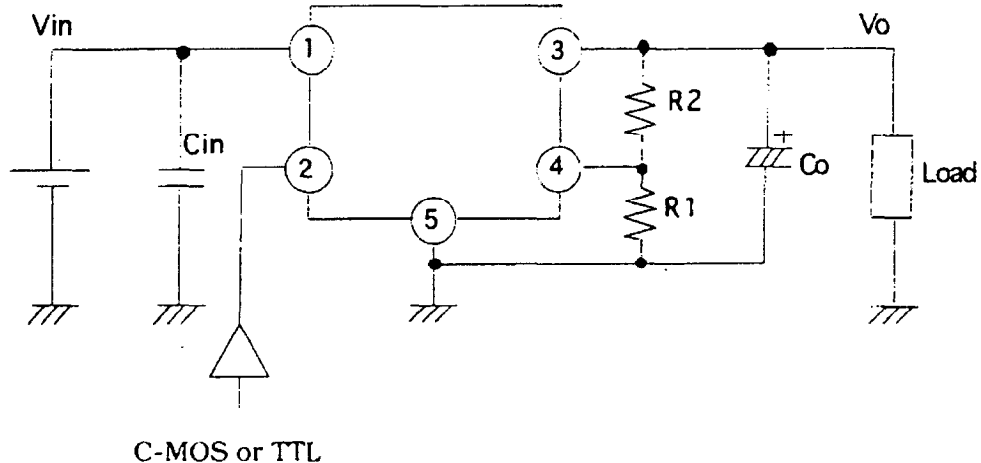

- (1) Please perform shortest wiring for connection between  $C_{in}$ ,  $C_o$  and the individual terminal or pin. There is case that oscillation occurs easily by kinds of capacitor and capacity. Before you use this device, you should confirm output voltage on your use mounting state.
- (2) The input terminal for ON/OFF output control ; ② is compatible with LS-TTL, and direct driving by TTL or C-MOS standard logic (RCA 4000 series) is also available. In case that ON/OFF terminal is not used, we recommend to connect the ON/OFF terminal directly to the input terminal : ① input voltage.
- (3) As voltage application under conditions that the device pin is inserted divergently or reversely, may occur the degradation of characteristics or breakdown of the device, please avoid it absolutely.

## 7.2 Thermal protection design

Internal power dissipation ( $P_d$ ) of device is obtained by the following equation.

$$P_d = I_o \times (V_{in} - V_o) + V_{in} \times I_q$$

If the ambient temperature and  $P_d$  at the device operating state, make the thermal design enough to radiate the heat as allows the device to operate within the safety operation area specified by the derating curve in para. 3.4. Insufficient radiation gives an unfavorable influence to the normal operation and reliability of the device.

In the case of no passage within the safety operational territory illustrated by the derating curve, the overheat protection circuit operates to let output fall down, please avoid keeping such condition for a long time.

**REFERENCE**

### 7.3 Static electricity

Good caution must be exercised against static electricity since this device consists of a bipolar IC. Following are some examples of preventive measures against excessive voltages such as caused by static electricity.

- (a) Human body must be grounded to discharge the static electricity from the body or cloth.
- (b) Anything that is in contact with the device such as workbench, inserter, or measuring instrument must be grounded.
- (c) Use a solder dip basin with a minimum leak current (isolation resistance 10M $\Omega$  or more) from the commercial power supply. Also the solder dip basin must be grounded.

### 7.4 Soldering

#### (1) Reflow soldering

It is recommended that within two times soldering be done at the temperature and the time within the temperature profile as shown in the figure. (The temperature shown in the figure is fin portion temperature of the device.) It is recommended that the second reflow become at the device which is the room temperature.

- (a) An infrared lamp used to heat up for soldering may cause a localized temperature rise in the resin. The temperature of resin portion should be within the temperature profile below.
- (b) The temperature sloping when soldering-reflow is 4 $^{\circ}$ C/s or less.

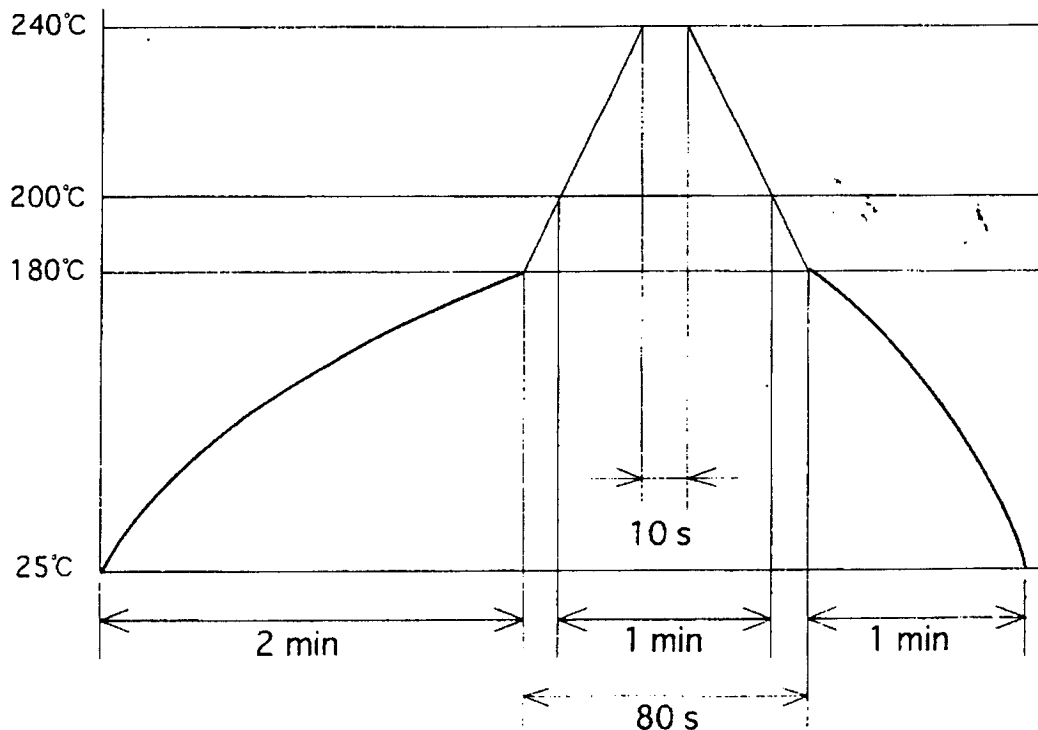

**REFERENCE**

(2) Dip soldering

We recommend that solder dip should be 260°C (Solder temp.) 10s or less and 1 time only. Please obey the note items below concerning solder reflow.

- (a) After solder dip, please do cooling naturally.
- (b) Please shall not give the mechanical stress or the impact stress to the device.

(3) Hand soldering

This device is basically designed for the soldering such as reflow soldering or dip soldering. In case when hand soldering is reluctantly needed for modification etc., it is recommended that only one hand soldering should be done at 260°C or less of soldering iron edge temperature, for 10s or less. Please be careful not to touch soldering iron edge to leads directly etc. in order not to give any stress to the leads.

Even within the above conditions regarding solder reflow, solder dip or hand soldering there is the possibility that the stress given to the terminals by the deformation of PCB makes the wire in the device package cut. In advance, please confirm fully at the actual application.

7.5 For cleaning

- (1) Solvent cleaning : Solvent temperature 45°C or less  
Immersion for 3 min or less
- (2) Ultrasonic cleaning : The effect to device by ultrasonic cleaning differs by cleaning bath size, ultrasonic power output, cleaning time, PCB size or device mounting condition etc. Please test it in actual using condition and confirm that doesn't occur any defect before starting the ultrasonic cleaning.
- (3) Applicable solvent : Ethyl alcohol, Methyl alcohol, Isopropyl alcohol

In case when the other solvent is used, there are cases that the packaging resin is eroded. Please use the other solvent after thorough confirmation is performed in actual using condition.

**REFERENCE**

### 7.6 Output voltage fine tuning

Connecting external resistors R1 and R2 to terminals 3, 4, 5 allows the output voltage to be fine tuned from 1.5V to 7. Refer to the figure below and "Paragraph 6.3 Output voltage adjustment characteristics" when connecting external resistors for fine tuning output voltage.

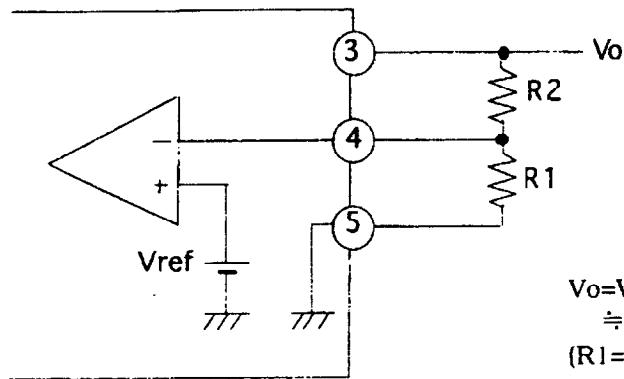

$$\begin{aligned} V_o &= V_{ref} \times (1 + R_2/R_1) \\ &\approx 1.25 \times (1 + R_2/1000) \\ (R_1 &= 1k\Omega, V_{ref} \approx 1.25V) \end{aligned}$$